

Contact Details

Before using the product, please check the guide pages at the front of this catalog.

Internet

<http://www.daikinpmc.com/en/>

For latest information, PDF catalogs and operation manuals

Throttle Valves/Throttle Valves with Check Valve

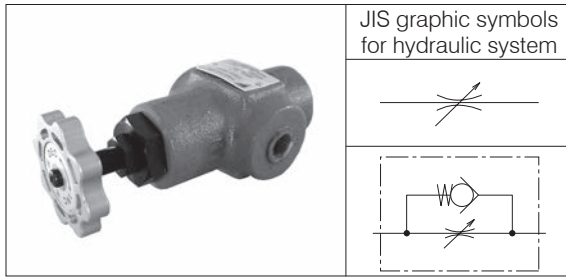

JIS graphic symbols for hydraulic system

Features

- Well balanced structure for pressure enables easy operation of the handle even at a high pressure.
- The compact design minimizes the installation space.
- Facilitates fine adjustment of the flow rate.

Nomenclature

※ - **HDFT** ※ - ※ ※ ※

1 2 3 4 5

1 Applicable fluid code

No designation: Petroleum-based hydraulic fluid, water-glycol hydraulic fluid
 F: Phosphate ester hydraulic fluid

2 Model No.

HDFT: H series throttle valve

3 Check valve code

No designation: Without check valve
 C: With check valve

4 Connections

G: Gasket mount type
 T: Screw connection type
 F: Flange connection type

5 Nominal diameter

03: 3/8
 06: 1/4
 10: 1/2
 16: 2

Specifications

Model code	Nominal diameter	Maximum operating pressure MPa {kgf/cm ² }	Maximum control flow rate L/min	Check valve Cracking pressure MPa {kgf/cm ² }	Mass kg	
HDFT(C)-G03	3/8	21 {210}	30	0.2 {2}	2.7	
HDFT(C)-T03					1.5	
HDFT(C)-G06	3/4		75		0.15 {1.5}	4.2
HDFT(C)-T06						3.6
HDFT(C)-F06			9.5			
HDFT(C)-G10	1 1/4		190	0.2 {2}	11	
HDFT(C)-T10					9.4	
HDFT(C)-F10			11 ^{*1}			
HDFT(C)-F16	2	470	0.2 {2}	21 ^{*1}		

Note: ^{*1} The mass of the flange mount type valve includes the mass of the flange and bolts.

Sub-plate model code

- The sub-plate is not provided with the valve. Order it separately if required by specifying the model code given in the table below.

Model code	Nominal diameter	Connection port diameter	Mass kg
HDFT-03M	3/8	Rc3/8	1.7
HDFT-06M	1/4	Rc1/4	3
HDFT-10M	1 1/4	Rc1 1/4	8

Refer to Page S-7 for the dimensions of the sub-plate.

Accessories

Connections	Model No.	Hexagon socket head cap bolt	Quantity	Tightening torque Nm {kgfcm}
Gasket mount type	HDFT(C)-G03	M10 × 70	4	48 to 63 {480 to 630}
	HDFT(C)-G06	M10 × 80	4	48 to 63 {480 to 630}
	HDFT(C)-G10	M12 × 45	6	92 to 122 {920 to 1220}
Flange connection type	Flange (JIS B 2291 SSA), O-ring, mounting bolts.			

Handling

- The flow rate will not be zero even when the flow rate adjusting handle is fully tightened due to the spool type configuration.
- The throttle valves can control the flow in both directions. However, with throttle valves with check valve, the flow in the reverse direction will be free flow.

Contact Details

Before using the product, please check the guide pages at the front of this catalog.

Internet

<http://www.daikinpmc.com/en/>

For latest information, PDF catalogs and operation manuals

Performance curves (viscosity: 32 mm²/s {cSt})

● HDFT(C)-×03

Handle revolution -
Flow rate characteristics

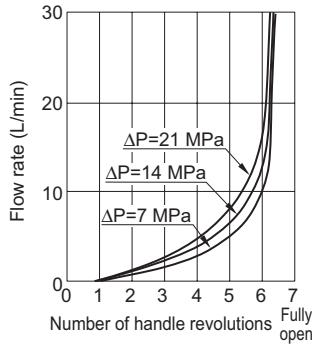

Pressure drop characteristics

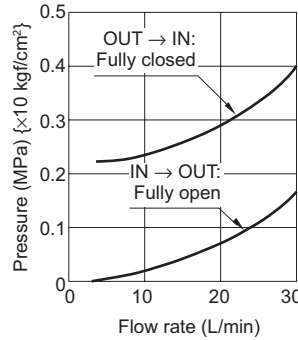

● HDFT(C)-×06

Handle revolution -
Flow rate characteristics

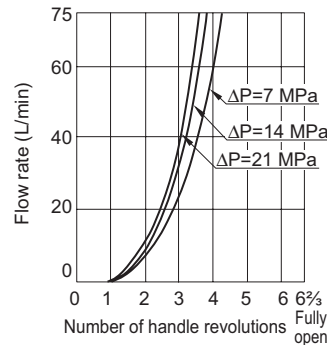

Pressure drop characteristics

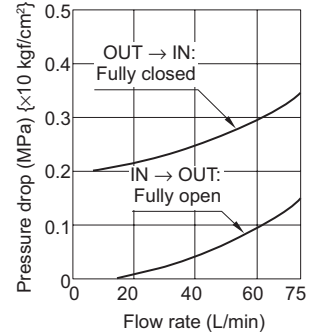

● HDFT(C)-×10

Handle revolution -
Flow rate characteristics

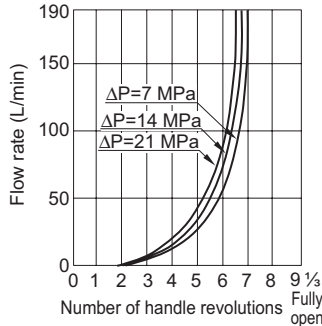

Pressure drop characteristics

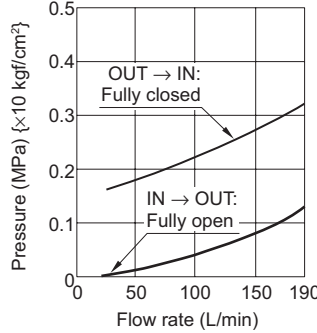

● HDFT(C)-F16

Handle revolution -
Flow rate characteristics

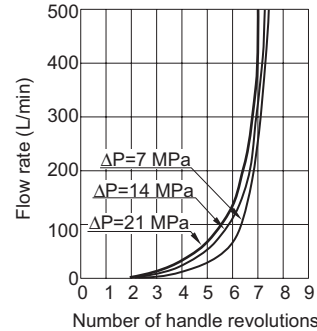

Pressure drop characteristics

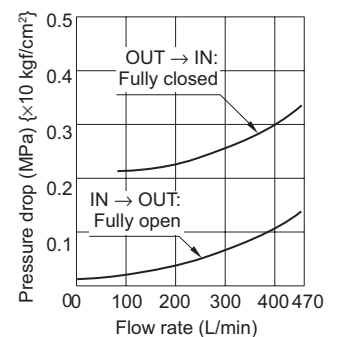

FLOW CONTROL VALVES

External dimension diagram

HDFT(C)-T××

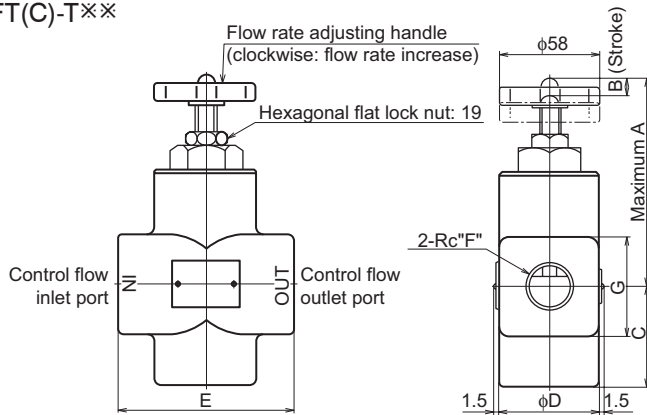

Model code	Dimensions						
	A	B	C	D	E	F	G
HDFT(C)-T03	103.5	7	44	44	72	3/8	φ44
HDFT(C)-T06	124.0	10	58	58	102	1/2	□60
HDFT(C)-T10	148.0	14	90	80	140	1 1/4	□80

HDFT(C)-F××

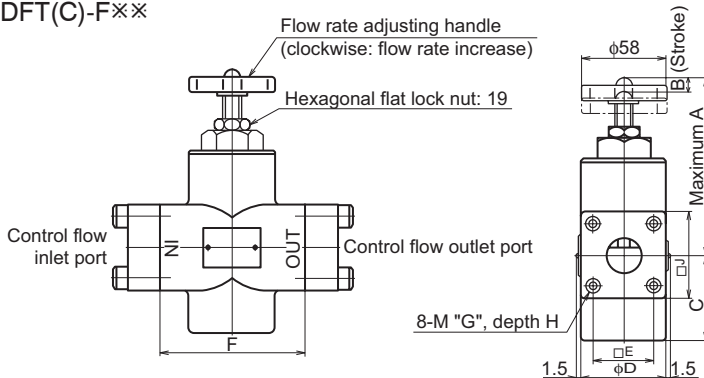

Model code	Dimensions								
	A	B	C	D	E	F	G	H	J
HDFT(C)-F06	124	10	58	58	40	100	10	15	60
HDFT(C)-F10	148	14	90	80	56	137	12	20	80
HDFT(C)-F16	170	20	112	90	73	158	16	27	100

Contact Details

Before using the product, please check the guide pages at the front of this catalog.

Internet

<http://www.daikinpmc.com/en/>

For latest information, PDF catalogs and operation manuals

External dimension diagram

HDFT(C)-G03,G06

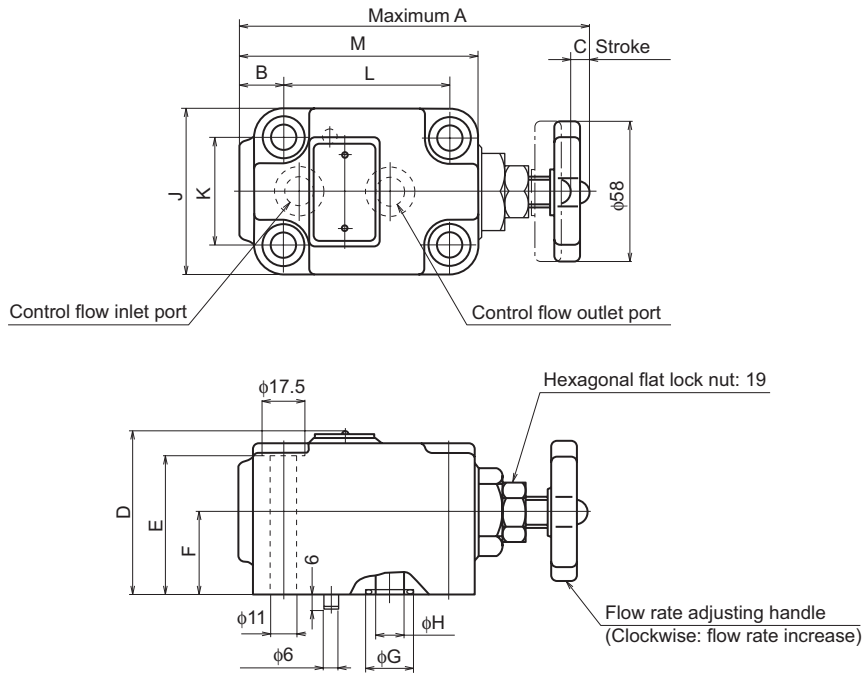

Model code	Dimensions											
	A	B	C	D	E	F	G	H	J	K	L	M
HDFT(C)-G03	147.5	18	7	66.5	55	34	22	14	64	44	70	98
HDFT(C)-G06	182.5	21	10	76.5	65	40	30	20	68	46	90	122

HDFT(C)-G10

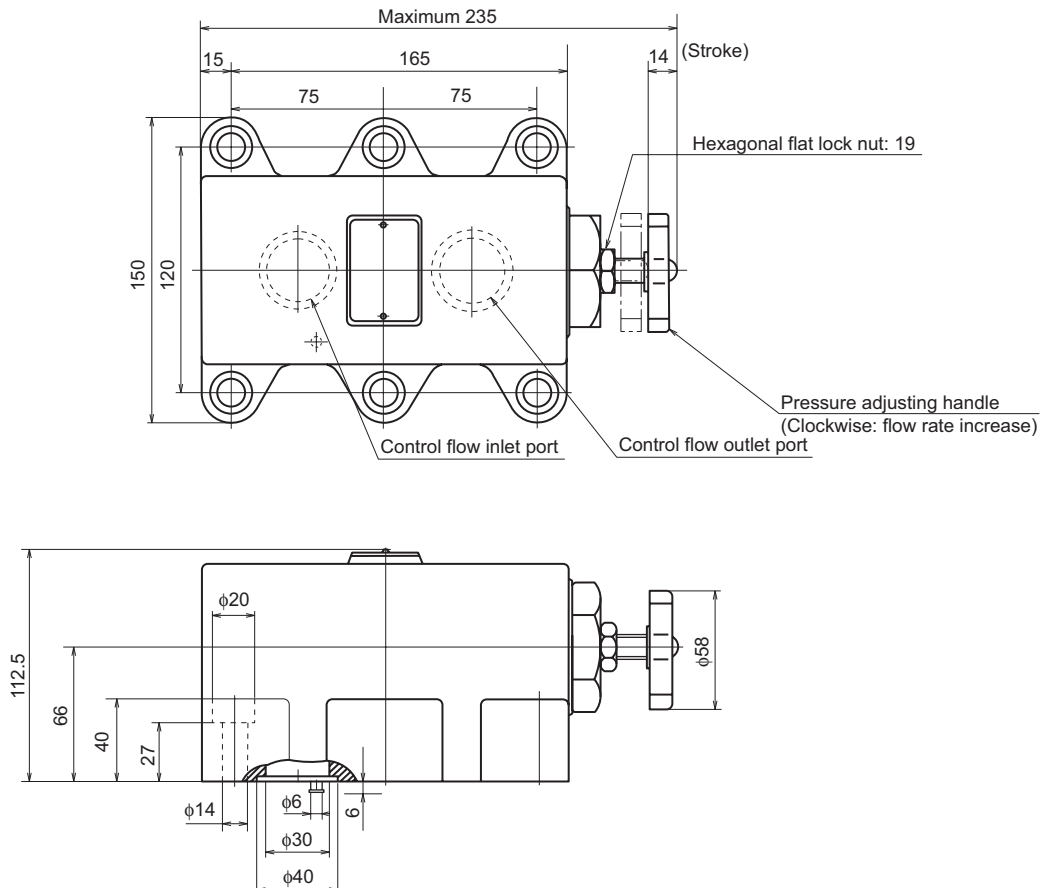

Sectional structural diagram

HDFT(C)-G**

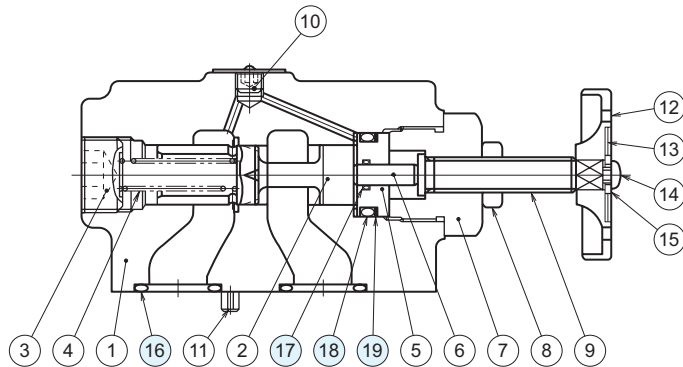

Sealing part table

Part No.	Name	Quantity	Part specifications		
			HDFT(C)-G03	HDFT(C)-G06	HDFT(C)-G10
16	O-ring	2	JIS B 2401 1B P18	JIS B 2401 1B G25	JIS B 2401 1B G35
17	O-ring	1	JIS B 2401 1B P5	JIS B 2401 1B P7	JIS B 2401 1B P8
18	O-ring	1	JIS B 2401 1B P20	JIS B 2401 1B P22.4	JIS B 2401 1B P36
19	Backup ring	1	JIS B 2407 Spiral P20	JIS B 2407 Spiral P22.4	JIS B 2407 Spiral P36

HDFT(C)-T**

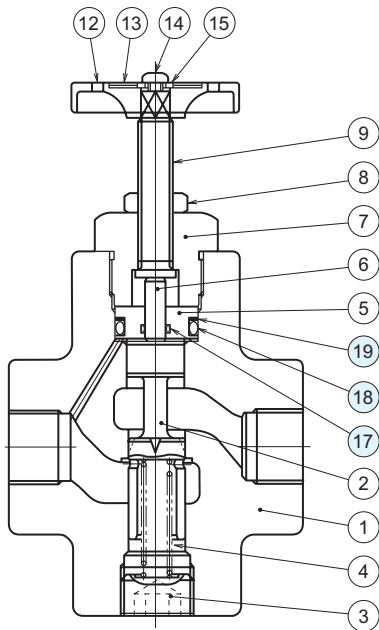

HDFT(C)-F**

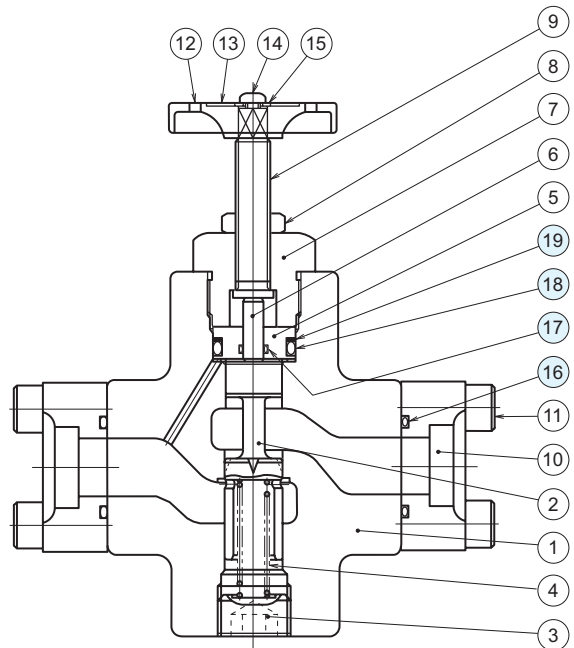

Sealing part table

Part No.	Name	Quantity	Part specifications		
			HDFT(C)-T03	HDFT(C)-T06	HDFT(C)-T10
17	O-ring	1	JIS B 2401 1B P5	JIS B 2401 1B P7	JIS B 2401 1B P8
18	O-ring	1	JIS B 2401 1B P20	JIS B 2401 1B P22.4	JIS B 2401 1B P36
19	Backup ring	1	JIS B 2407 Spiral P20	JIS B 2407 Spiral P22.4	JIS B 2407 Spiral P36

Part No.	Name	Quantity	Part specifications		
			HDFT(C)-F06	HDFT(C)-F10	HDFT(C)-F16
16	O-ring	2	JIS B 2401 1B G30	JIS B 2401 1B G40	JIS B 2401 1B G60
17	O-ring	1	JIS B 2401 1B P7	JIS B 2401 1B P8	JIS B 2401 1B P8
18	O-ring	1	JIS B 2401 1B P22.4	JIS B 2401 1B P36	JIS B 2401 1B P48
19	Backup ring	1	JIS B 2407 Spiral P22.4	JIS B 2407 Spiral P36	JIS B 2407 Spiral P48