

# Pilot Operated Relief Valve

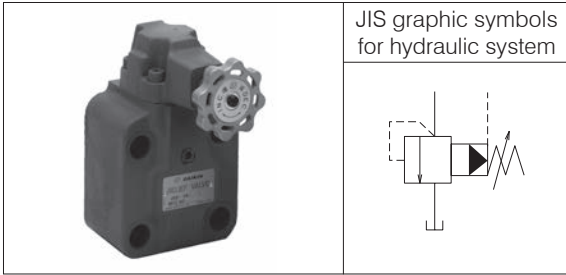

## Features

- Achieves stable pressure control over a wide range of flow rates and also works as a safety valve.
- The main circuit pressure can be controlled remotely by connecting a relief valve for remote control to the vent port.
- The vent port can be used to provide the function of an unload valve.
- High-vent type units are available as options.

## Nomenclature

⊗ - **JRB** - ⊗ ⊗ ⊗ - ⊗ ⊗ - ⊗ ⊗

1      2      3      4      5      6      7

### 1 Applicable fluid code

No designation: Petroleum-based hydraulic fluid, water-glycol hydraulic fluid

F: Phosphate ester hydraulic fluid

### 2 Model No.

JRB: J series pilot operated relief valve

### 3 Connections

G: Gasket mount type

T: Screw connection type

F: Flange connection type

### 4 Nominal diameter

06: 3/4, 10: 1 1/4, 16: 2

### 5 Pressure adjustment range

1: Up to 7 MPa {Up to 70 kgf/cm<sup>2</sup>}

3: Up to 21 MPa {Up to 210 kgf/cm<sup>2</sup>}

### 6 Vent type code

No designation: Low-vent type

V: High-vent type

### 7 Design No.

**(The design No. is subject to change)**

12: Nominal diameter 16 (2)

13: Nominal diameter 06 (3/4), 10 (1 1/4)

## Specifications

Model code	Nominal diameter	Pressure adjustment range*1 MPa {kgf/cm <sup>2</sup> }	Maximum flow rate L/min	Mass kg
JRB-G06-1-13	3/4	Up to 7 {Up to 70}	170	6
JRB-G06-3-13		Up to 21 {Up to 210}		
JRB-T06-1-13		Up to 7 {Up to 70}		4.6
JRB-T06-3-13		Up to 21 {Up to 210}		
JRB-F06-1-13		Up to 7 {Up to 70}		
JRB-F06-3-13		Up to 21 {Up to 210}		
JRB-G10-1-13	1 1/4	Up to 7 {Up to 70}	380	9
JRB-G10-3-13		Up to 21 {Up to 210}		
JRB-T10-1-13		Up to 7 {Up to 70}		8.5
JRB-T10-3-13		Up to 21 {Up to 210}		
JRB-F10-1-13		Up to 7 {Up to 70}		
JRB-F10-3-13		Up to 21 {Up to 210}		
JRB-F16-1-12	2	Up to 7 {Up to 70}	700	20
JRB-F16-3-12		Up to 21 {Up to 210}		

Note: \*1 The minimum adjustment pressure varies depending on the flow rate. See the minimum adjustment pressure characteristics for details.

Model code	Pressure change MPa {kgf/cm <sup>2</sup> } per handle revolution
JRB-⊗⊗⊗-1	2.1 {21}/revolution
JRB-⊗⊗⊗-3	5.2 {52}/revolution

## Sub-plate model code

- The sub-plate is not provided with the valve. Order it separately as required by specifying the model code given in the table below.

Model code	Nominal diameter	Connection port diameter	Mass kg
JRB-06M	3/4	Rc3/4	3.5
JRB-06M08		Rc1	
JRB-10M	1 1/4	Rc1 1/4	6.5
JRB-10M12		Rc1 1/2	

Refer to Page S-5 for the dimensions of the sub-plate.

## Accessories

Connections	Model No.	Hexagon socket head cap bolt	Quantity	Tightening torque N·m {kgf·cm}
Gasket mount type	JRB-G06	M16 × 85	4	250 to 300 {2500 to 3000}
	JRB-G10	M18 × 90	2	322 to 402 {3220 to 4020}
		M18 × 110	2	
Flange connection type	Flange (JIS B 2291 SSA), O-ring, mounting bolts			

## Handling

- Directly connect the tank piping of the valve to the tank without merging it with other tank piping and arrange it such that the back pressure of the tank port can be maintained at no greater than 0.5 MPa {5 kgf/cm<sup>2</sup>}.
- When using the valve in combination with a direct operated relief valve for remote control, connect the remote control valve to the vent port.  
Since excessive internal volume of the vent piping may lead to vibration, use steel pipes with an inner diameter of 4 mm maximum and thick walls for piping.
- When using the valve as a safety valve, set the pressure 1 to 1.5 MPa {10 to 15 kgf/cm<sup>2</sup>} higher than the pressure set for the hydraulic circuit.
- Use a valve with the flow rate given in the table below or higher since the pressure setting may be unstable if the flow rate is too low.

Model No.	Minimum flow rate L/min
JRB-×06	7
JRB-×10	15
JRB-F16	28

- The time required to switch from the unload to on-load state can be reduced by using the high-vent type.
- Since JRB-F16 has a structure that suppresses increase in the sound of flow as the flow rate increases, arrange a 2B pipe in a straight line for at least the first 30 cm of the tank piping from the valve.
- The direction of the pressure adjusting handle can be changed by rearranging the covers. (See external dimension diagrams [I], [II], [III] and [IV].)

## Performance curves (viscosity: 32 mm<sup>2</sup>/s {cSt})

- Flow rate - Pressure characteristics

JRB-×06

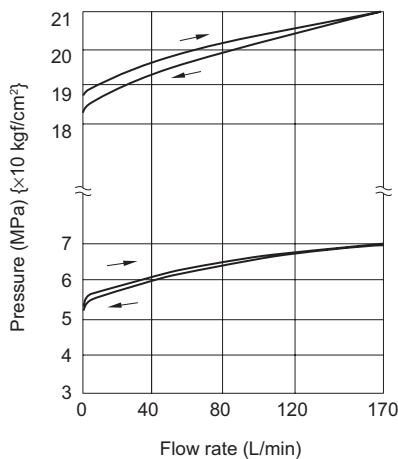

JRB-×10

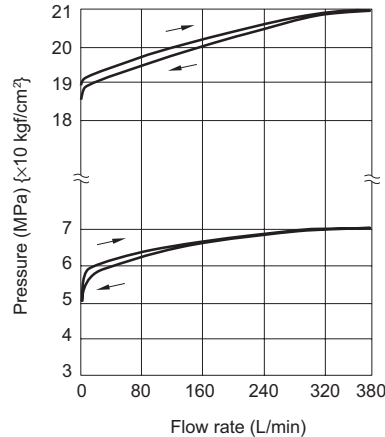

JRB-F16

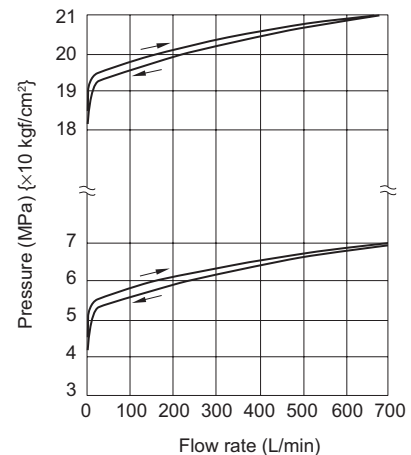

- Flow rate - Vent pressure characteristics (vent port: unload state)
- Minimum adjustment pressure characteristics (with the handle fully open)

JRB-×06-× (V)

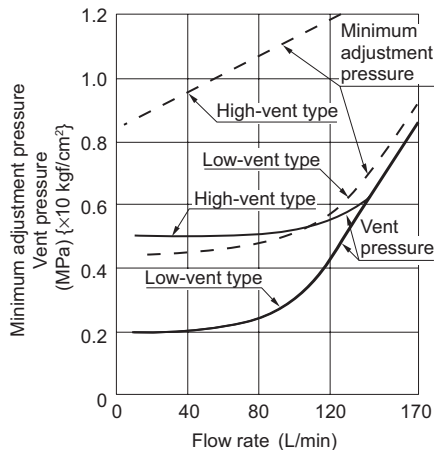

JRB-×10-× (V)

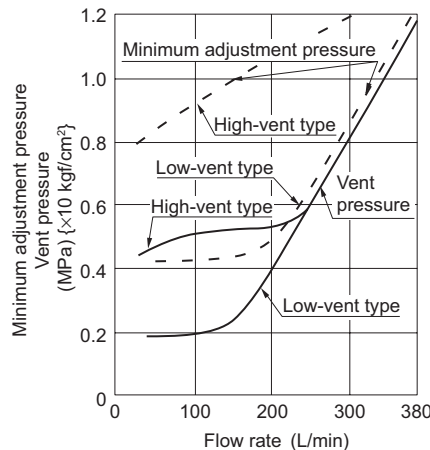

JRB-F16-× (V)

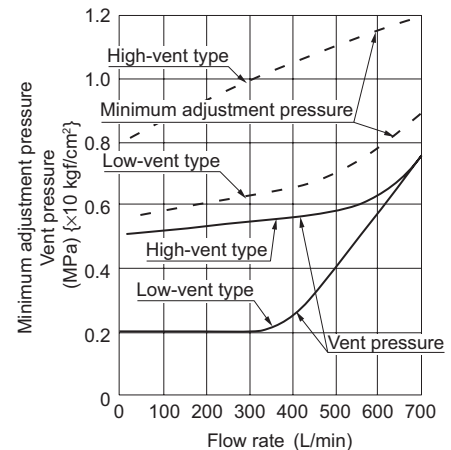

# Contact Details

Before using the product, please check the guide pages at the front of this catalog.

Internet

<http://www.daikinpmc.com/en/>

For latest information, PDF catalogs and operation manuals

## External dimension diagram

JRB-G※※-※※

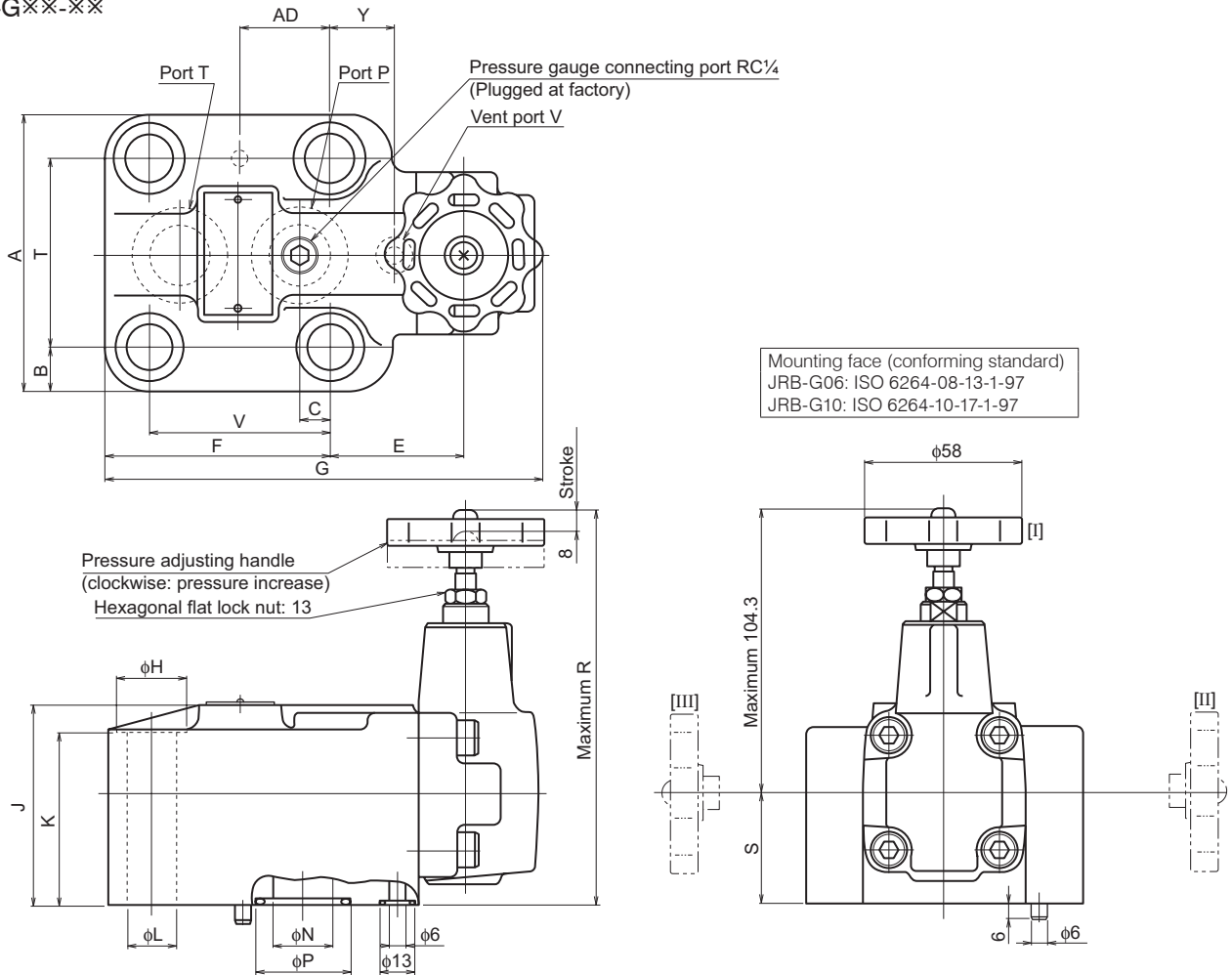

Model No.	A	B	C	E	F	G	H	J	K	L	N	P	R	S	T	V	Y	AD
JRB-G06	102	16.1	11.1	49.5	83	161.5	26	73	63	18	22	35	144.3	40	69.8	66.7	23.8	33.3
JRB-G10	120	18.8	0.9	70.6	107.9	207.5	32	98	62, 82	21	30	40	154.3	50	82.5	88.9	31.8	44.5

Note: The value of 62 given for dimension K of JRB-G10 is for the two mounting holes at the left side among the four. The corresponding value for the two mounting holes at the right side (handle side) is 82.

JRB-T※※-※※

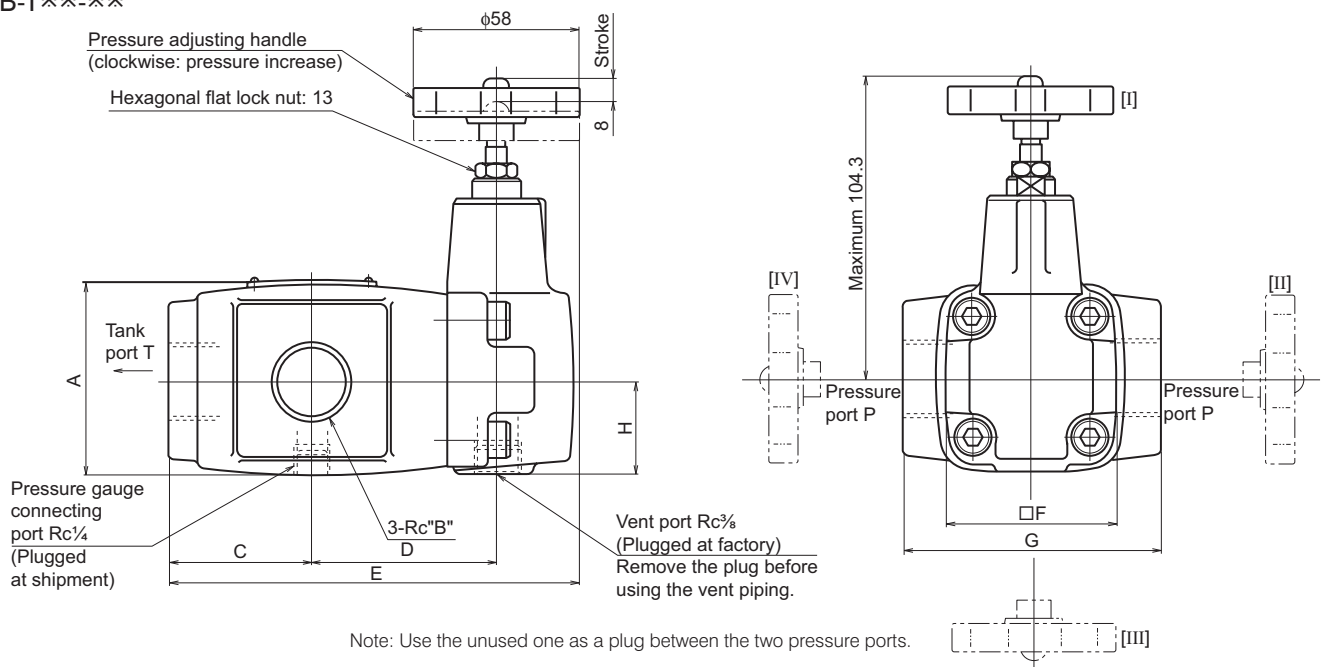

Note: Use the unused one as a plug between the two pressure ports.

Model No.	A	B	C	D	E	F	G	H
JRB-T06	67	3/4	50	65	144	60	90	32.5
JRB-T10	100	1 1/4	70	71.5	170.5	94	138	47

## Contact Details

Before using the product, please check the guide pages at the front of this catalog.

Internet

<http://www.daikinpmc.com/en/>

For latest information, PDF catalogs and operation manuals

## External dimension diagram

JRB-F※※-※※

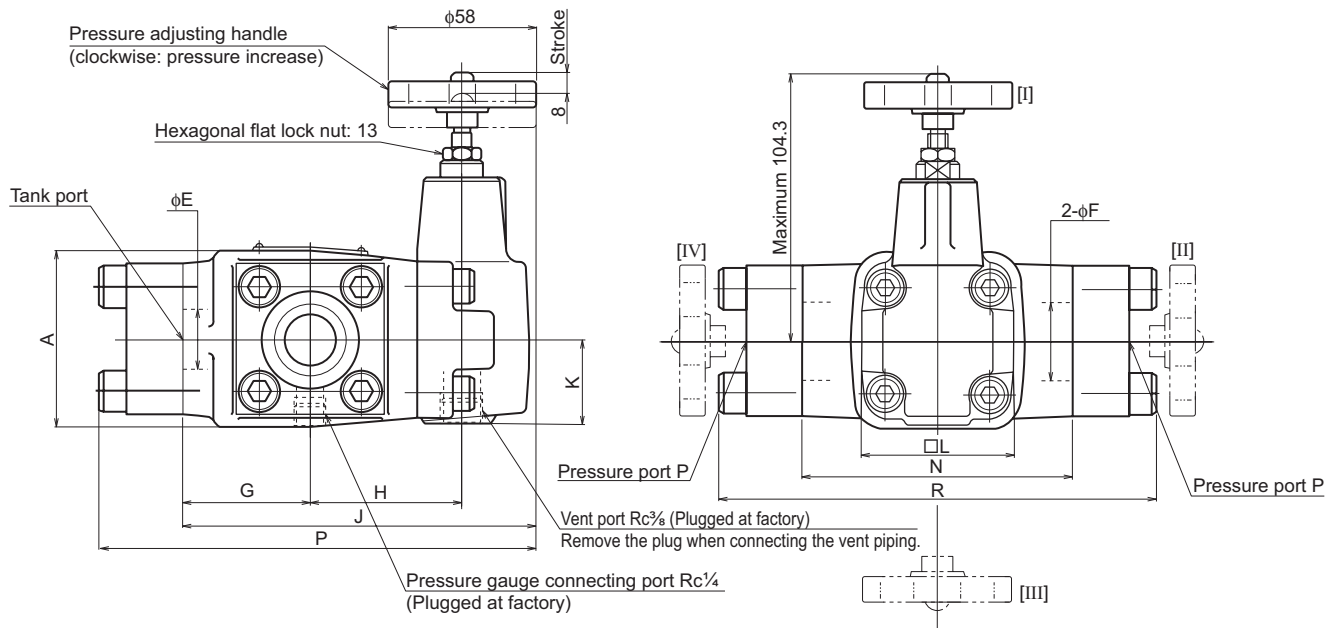

Model No.	A	C	D	E	F	G	H	J	K	L	N	P	R	Flange (pair)	Hexagon socket head cap bolt
JRB-F06	74	10	20	23	20	50	59.5	138.5	32.5	60	106	170.5	170	JIS B 2291 SSA20, 3 pcs.	M10 × 40, 12 pcs.
JRB-F10	100	12	20	31	31	75	71.5	175.5	47	94	132	215.5	212	JIS B 2291 SSA32, 3 pcs.	M12 × 45, 12 pcs.
JRB-F16	120	16	26	50	40	71.5	105	206.5	59	118	140	258.5	244	JIS B 2291 SSA50, 3 pcs.	M16 × 60, 12 pcs.

## Sectional structural diagram

JRB-G※※

JRB-F※※

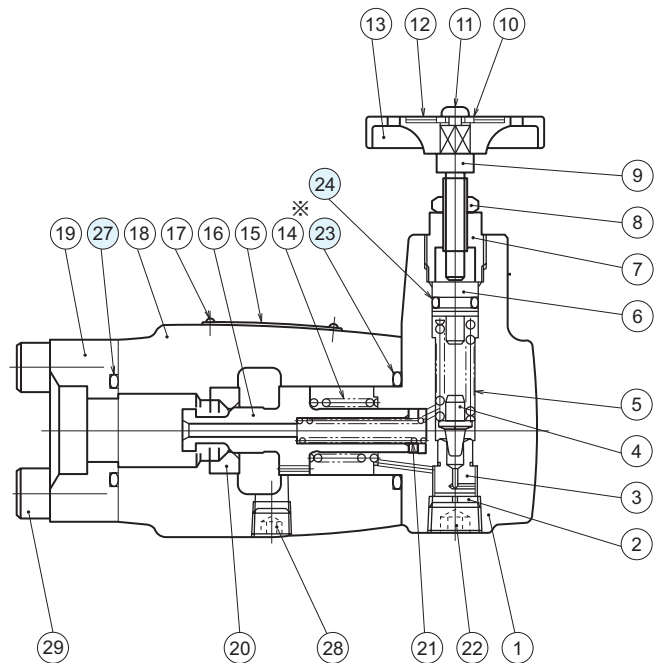
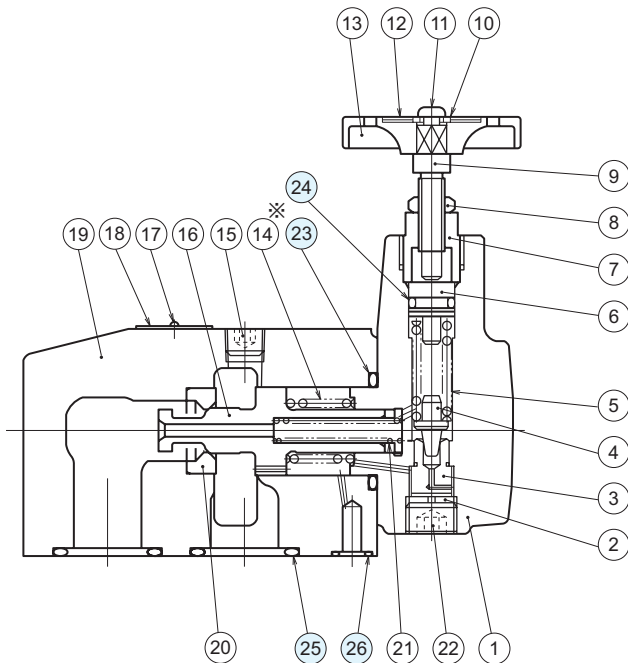

※ Spring (14) is only applicable with the high-vent type.

## Sealing part table

Part No.	Name	Quantity	Part specifications						
			JRB-G06	JRB-G10	JRB-T06	JRB-T10	JRB-F06	JRB-F10	JRB-F16
23	O-ring	1	JIS B 2401 1BP31	JIS B 2401 1BP42	JIS B 2401 1BP31	JIS B 2401 1BP42	JIS B 2401 1BP31	JIS B 2401 1BP42	JIS B 2401 1BG60
24	O-ring	1	JIS B 2401 1AP11	JIS B 2401 1AP11	JIS B 2401 1AP11	JIS B 2401 1AP11	JIS B 2401 1AP11	JIS B 2401 1AP11	JIS B 2401 1AP11
25	O-ring	2	JIS B 2401 1BG30	JIS B 2401 1BG35	-	-	-	-	-
26	O-ring	1	JIS B 2401 1BP10	JIS B 2401 1BP10	-	-	-	-	-
27	O-ring	3	-	-	-	-	JIS B 2401 1BG30	JIS B 2401 1BG40	JIS B 2401 1BG60